

Superaqua 3

Ultrasonic Meter for Domestic Water Networks

User Manual



Table of Contents

1.	Contact of the Organization	3
2.	Safety Rules and Precautions	3
2.1.	Information on the User Manual Relating to Legal Notice	3
2.2.	Handling, Transport and Storage	4
2.3.	Disposal Rules for Superaqua 3	4
3.	Technical Characteristics	5
3.1.	Metrological Data	5
3.2.	Dimensions	6
3.3.	Power Supply	6
4.	Installation and Checks	7
4.1.	Installation of Superaqua 3	7
4.2.	Check the Correct Location of Superaqua 3	7
4.2.1.	Environment	7
4.2.2.	Installation	8
4.3.	Non-return Valve	8
4.4.	Maintenance and Cleaning	8
5.	Understanding the Superaqua 3 Interface	9
5.1.	Understand the Face Plate	9
5.2.	Screen Display Information	10
5.2.1.	Display Sequence	10
5.2.2.	Display Characteristics	10
5.3.	Understand the events on the LCD screen	11
5.3.1.	Set LCD display symbols	11
5.3.2.	Understanding Display Codes	12
6.	Communication Systems	12
6.1.	Global View of Communication Systems	12
7.	ParamApp® Android Application	13
7.1.	Presentation of ParamApp®	13
7.1.1.	Features	13
7.1.2.	Datalog	13
7.2.	Installation ParamApp® Android Application	13
8.	Certifications and Regulations	13

1. Contact of the Organization

Sontex France SAS
18, Avenue de l'Escadrille Normandie-Niemen, Blagnac, Occitanie, 31700
France

Phone: +33 5 6111 23 56
sontex@sontex.ch
www.sontex.com

Reproduction of these instructions or parts of them in whatever form is not permitted without express written permission from the publisher.

The figures and information in these instructions are subject to technical changes that become necessary to improve the product.

2. Safety Rules and Precautions

2.1. Information on the User Manual Relating to Legal Notice

This guide is intended for trained specialized personnel. For this reason, no basic working steps are included.

DANGER



Danger

This safety warning indicates a high risk which will result in serious personal injury or death.
Measures to avoid incidents

WARNING



Warning

This safety warning indicates medium risk that could result in serious injury.
Measures to avoid incidents

CAUTION



Caution

This safety warning indicates a low risk which could result in minor injury or mechanical damage.
Measures to avoid incidents

NOTICE



Notice

Indicates an action or measure which, if performed incorrectly, may have an indirect effect on the operation of the device.
Measures to avoid malfunctions

COMMENT



Comment

Comment, provides information and recommendations for efficient and trouble-free operation.
Measures to avoid malfunctions

REFERENCE



Reference

Refers to additional sources

2.2. Handling, Transport and Storage

The manufacturer assumes no responsibility if the following safety instructions and instructions are followed precautionary measures are not observed:

- Any changes made to the unit without the prior written consent of the manufacturer will result in the following leads to the immediate expiration of product liability and warranty.
- Installation, operation, maintenance and decommissioning of this device may only be carried out by trained personnel, by qualified specialist personnel who have been instructed by the manufacturer, operator or owner to of the plant authorized. The specialist must have read and understood all of these operating instructions and the have read and understood the install-ation instructions and have understood the instructions contained therein. to the rules of the law.
- Check all connections, settings and technical data of peripheral devices.
- Open housing or parts of the housing are completely forbidden.
- The specified classifications for mechanical loads (e.g. pressure, temperature, etc.) must be observed. Protection class (IP) etc) must not be exceeded.
- Only operate the system under the specified ambient conditions and installation positions.
- Protect the system against over-voltage. In particular, electrical welding is prevented on the associated equipment.
- None of the information contained in this manual or in any other document releases the user from the responsibility for plan-ners assessment of the respective system configuration with regard to functionality and operational safety.
- The local labor and safety laws and regulations must be observed.

2.3. Disposal Rules for Superaqua 3

WARNING



Warning

The device must not be opened. The battery is permanently installed and cannot be changed.

This device must not be disposed together with the domestic waste. Please return it to the manufacturer for recycling.



3. Technical Characteristics

3.1. Metrological Data

	Ref		AXT	BXT	CXT	AXT	CXT	DXT	HXT	AXT	BXT	DXT	EXT
Pipe definition	DN		15	15	15	20	20	20	20	25	25	25	25
	Thread		G3/4" B	G3/4" B	G3/4" B	G1" B	G1" B	G1" B	G1" B	G1"1/4 B	G1"1/4 B	G1"1/4 B	G1"1/4 B
	Material		CW617N						CW724R	CW617N			
Pipe Length	L	mm	110	165	170	190	105	130	165	260	200	175	260
Continuous Flow Rate	Q ₃	m ³ /h	2.5	2.5	2.5	4	4	4	4	10	10	10	6.3
Overload Flow Rate	Q ₄	m ³ /h	3.125	3.125	3.125	5	5	5	5	12.5	12.5	12.5	7.9
Transitional Flow Rate	Q ₂	L/h	8	8	8	13	13	13	13	32	32	32	21
Min. Flow Rate	Q ₁	L/h	5	5	5	8	8	8	8	20	20	20	13
Starting Flow Rate	Q _{START}	L/h	2.5	2.5	2.5	4	4	4	4	10	10	10	6
Pressure Drop Class @Q ₃	ΔP	-	ΔP25					ΔP40	ΔP65	ΔP40			ΔP25
Measuring range	R	-	R500										

	Ref		AXT	AXT	AXT
Pipe definition	DN		32	40	50
	Thread		G1 1/2" B	G2" B	G2" 1/2 B
	Material		CW617N		
Pipe Length	L	mm	260	300	300
Continuous Flow Rate	Q ₃	m ³ /h	10	16	25
Overload Flow Rate	Q ₄	m ³ /h	12.5	20	31
Transitional Flow Rate	Q ₂	L/h	32	51	80
Min. Flow Rate	Q ₁	L/h	20	32	50
Starting Flow Rate	Q _{START}	L/h	10	16	25
Pressure Drop Class @Q ₃	ΔP	-	ΔP25		
Measuring range	R	-	R500		

3.2. Dimensions

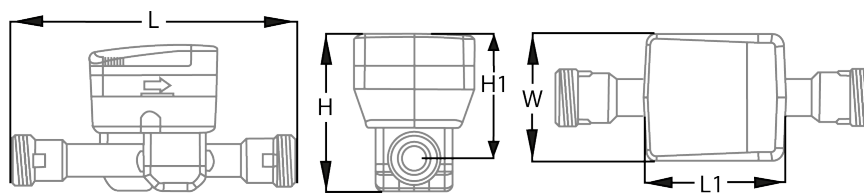

Dimensions	DN	15	20	25	32	40	50
	Thread	G3/4" B	G1" B	G1"1/4 B	G1" 1/2 B	G2" B	G2"1/2 B
Weight	kg	0.8	1	1.4	1.5	1.9	2.4
Height (H1)	mm	77	77	77	77	77	77
Total Height (H)	mm	98	98	98	101	107	115
Width (W)	mm	76	76	76	76	76	76
Housing Length (L1)	mm	87	87	87	87	87	87
Length (L)	mm	110	105	175	260	300	300
		165	130	200			
		170	165	260			
			190				
		220					

3.3. Power Supply

Type	Lithium battery
Lifetime	Up to 16 Years*

* Depending on sending interval of radio telegram, telegram length operating temperature.

4. Installation and Checks

NOTICE



Notice

The meter must be installed in compliance with the requirements of ISO 4064 and the EC Type Examination Certificate. Medium: Water without additives.

REFERENCE



Reference

Detailed instructions can be found in the enclosed «Installation guide», which are enclosed with every package of the product.

4.1. Installation of Superaqua 3

1. Thoroughly flush out the pipes before installing the meter.
2. The meter has to be installed so that the direction of the arrow on the meter housing corresponds to the direction of flow.

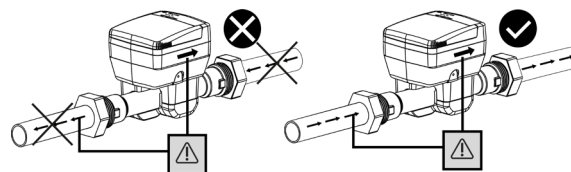

3. Remove old seals and clean sealing faces. The installation of the meter should not be done with force or strain, make sure that the meter is aligned.

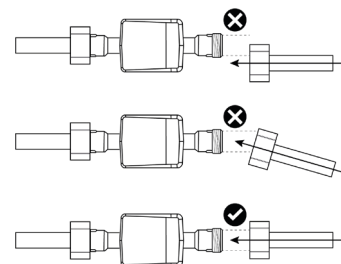

4. Remove old seals and clean sealing faces.
5. Site-provided seals must be suitable for the purpose and comply with the local guidelines and directives. Only fit the newly supplied seals (the seals should not intrude into the pipeline). No liability is accepted for consequential damage resulting from the use of third-party seals such as corrosion to sealing surfaces and threads.
6. Simultaneously manually screw home the meter fittings on both sides and then tighten in opposing directions using a suitable tool (minimum torque 30 Nm, maximum torque 50 Nm).

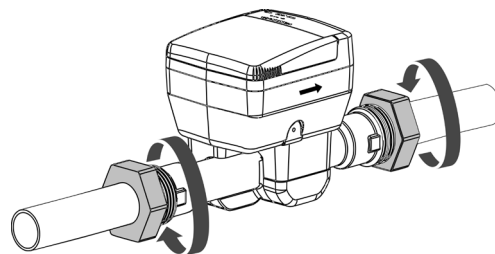

7. Slowly fill the pipeline with water on completion of the installation. Avoid the collection of air bubbles in the meter during the installation process.

4.2. Check the Correct Location of Superaqua 3

4.2.1. Environment

- The *Superaqua 3* must not exceed extreme conditions: max 70° C / 158° F (no more than 2 weeks at 35° C / 95° F); min -20° C / -4° F (2 weeks below 0° C / 32° F).

- Although the *Superaqua 3* is IP68, avoid an environment in which it would have to undergo prolonged or repeated immersions.

4.2.2. Installation

- Water temperature: max +50 °C / +122 °F; min +0.1 °C / +32 °F.

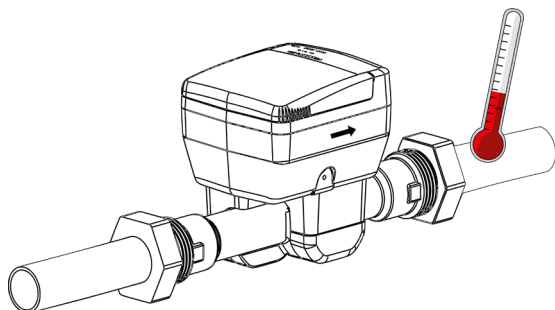

- The pressure should not exceed 16 bar.

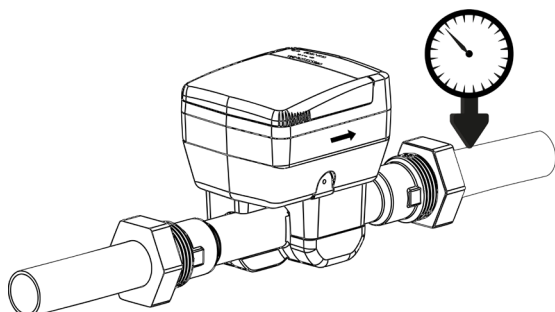

- Refer to the arrow on the side of the meter for the correct installation location (water must flow in the direction of the arrow).

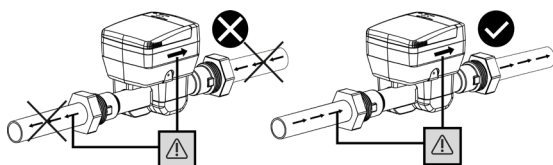

4.3. Non-return Valve

Some *Superaqua 3* references can be delivered with a non-return valve (accessory) (nominal diameter DN15 - DN40). The non-return valve must be mounted at the meter outlet.

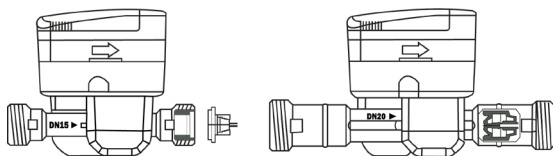

4.4. Maintenance and Cleaning

CAUTION



Caution

Do not clean it with solvents or abrasives as these may damage the plastic cover. If necessary, use a damp cloth or sponge.

5. Understanding the Superaqua 3 Interface

5.1. Understand the Face Plate

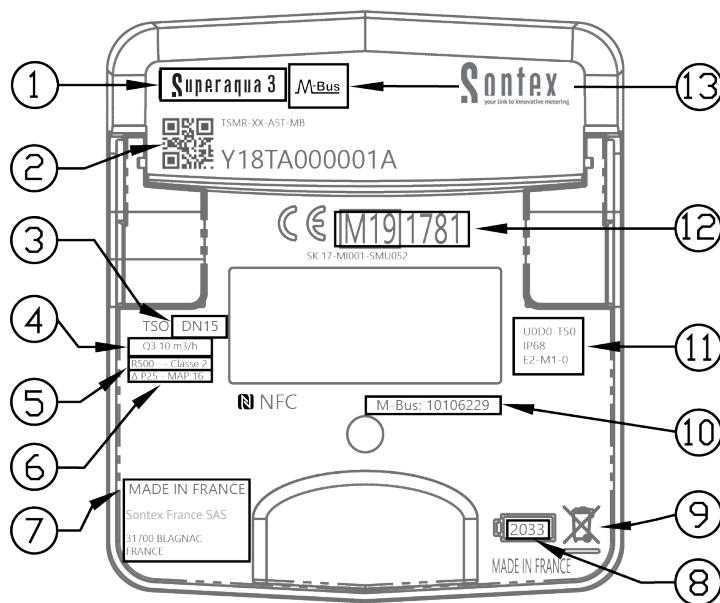

Legend of the Face Plate			
1	Name according to MID commercial name CE marking	8	Battery Expiration Date
2	Serial number, PN and associated datamatrix	9	Waste disposal mode
3	MID name - diameter	10	Communication ID
4	Nominal flow Q ³	11	Specific and technical approval
5	Ratio (Q ³ / Q ¹), accuracy Class 2	12	CE Marking according to MID, code of certifying lab
6	Pressure loss class, MAP	13	Communication system
7	Manufacturer, Address		

5.2. Screen Display Information

5.2.1. Display Sequence

To show the data read by the meter in the display, various windows have been created as functions that can display the assigned system information.

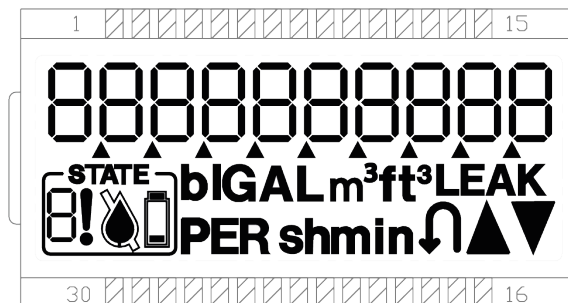

The LCD screen changes automatically to display the following information: net or forward volume, reverse volume, flow rate, events, firmware version, flow direction, meter state.

The basic display sequence is defined in two cycles, one main cycle and a secondary which launches after 120 seconds.













The basic display sequence:			The second sequence of the display every 120s:		
LCD screen	Description	Display time	LCD screen	Description	Display time
	Volume (Forward or Net)	10s		Display all segment ON	2s
	Flow rate	2s		Display all segment OFF	2s
	Events (if events are set)	2s		Display metrology FW version and CRC	2s
	Service (if service errors are set)	2s			

5.2.2. Display Characteristics

Display Indication	LCD 10 digits
Units	m ³ , L, Hour
Displayed Values	Volume, Flow, Reverse Flow, Display Test, Events and Alarms Status, F/W Version
Events and Alarms	Reverse Flow, Low Battery, Leakage, Air Bubbles, Burst, Frost, Heat, Dry, Over Temperature, No Consumption

5.3. Understand the events on the LCD screen

5.3.1. Set LCD display symbols

Name	Symbol	Information
Flow Direction		Instant flow is positive.
		Instant flow is negative.
Index Indicator		Set when the screen is displaying the positive index (forward volume), (with or without water in the pipe).
		The display shows the net volume (with or without water in the pipe).
		Set when the screen is displaying the negative index.
Water Detection		This symbol is displayed when the meter detects water.
		This symbol is displayed when the meter does not detect water.
Reverse Flow		If a defined volume is detected in the opposite direction.
Leakage		This symbol is displayed when there is high consumption for a long time.
Exclamation Mark		This symbol is displayed when a service event or error occurs.
Low Battery		This symbol is displayed when the battery is low.
Test Mode		The meter is in test mode.
Idle Mode		Display segment off.

5.3.2. Understanding Display Codes

This summary shows all possible events which require attention by the user.

Display Codes	Events	Conditions
E1	Reserved	
E2	Air Bubbles	Air is detected in the pipe.
E3	Burst	A leak is detected.
E4	Overload	High instantaneous flow
E5	Frost	Low water temperature
E6	Heat	High water temperature
E7	Over temperature	High ambient temperature
E8	No consumption	Water no longer circulates
S	Service	Please contact the service

NOTICE



Notice

If error condition is still active after the clearing delay it, it will not be cleared.

6. Communication Systems

The *Superaqua 3* is available in different communication systems, below you can find an overview of it.

6.1. Global View of Communication Systems

Naming	Wireless
LW8	MultiCom: simultaneous LoRaWAN 868 MHz and wM-Bus 868 MHz
LW	LoRaWAN EU 868 MHz 1.0.3
W8	wM-Bus 868 MHz
W4	wM-Bus 434 MHz

7. ParamApp® Android Application

7.1. Presentation of ParamApp®

ParamApp® is a powerful and user-friendly Android application developed by Sontex France SAS dedicated to commissioning, configuration and diagnostics of smart devices or smart meters directly on site, with a smartphone and through NFC.

7.1.1. Features

With a full range of possibilities, you can configure and diagnose your setup:

- Modification of radio modules
- Pulse configuration (pulse weight, pulse length)
- Reading out the events for detailed inspections on site
- Setup of alarms detection (threshold parameters, durations)

7.1.2. Datalog

Various history data can be extracted from the meter:

- Temperature (minimum, average, maximum)
- Flowrate (minimum, average, maximum)
- Volume (minimum, average, maximum)
- Events and alarms

The time granularity can be chosen for a precise analysis (hourly, daily, monthly, yearly), and data can be exported in CSV format.



7.2. Installation ParamApp® Android Application

ParamApp is a powerful and user-friendly software tool developed by Sontex France SAS dedicated to the commissioning, installation and configuration of smart devices or smart meters directly on site. With a full range of possibilities, you can configure and configure your live devices. Download our application on Google Play.

8. Certifications and Regulations

Certificates and declarations of conformity are available at www.sontex.com

